

# ILLUSTRATIVE EXAMPLE - ERIE TOWNSHIP MINIMUM LOT DIMENSIONS (DRAFT 11-14)

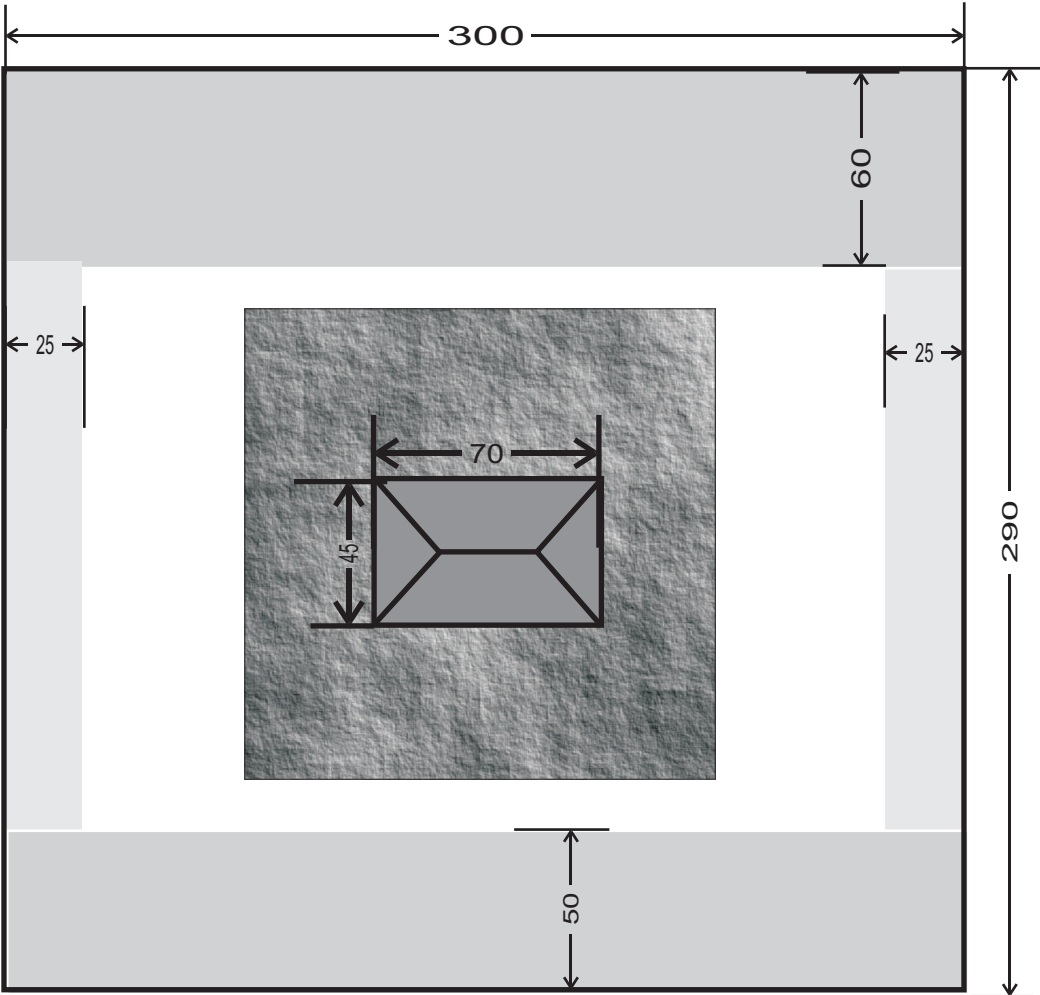

**AP Zoning District**  
 Min Lot Size= 87,120 (2 AC.)  
 Max Lot Coverage= 21,780 (25%)

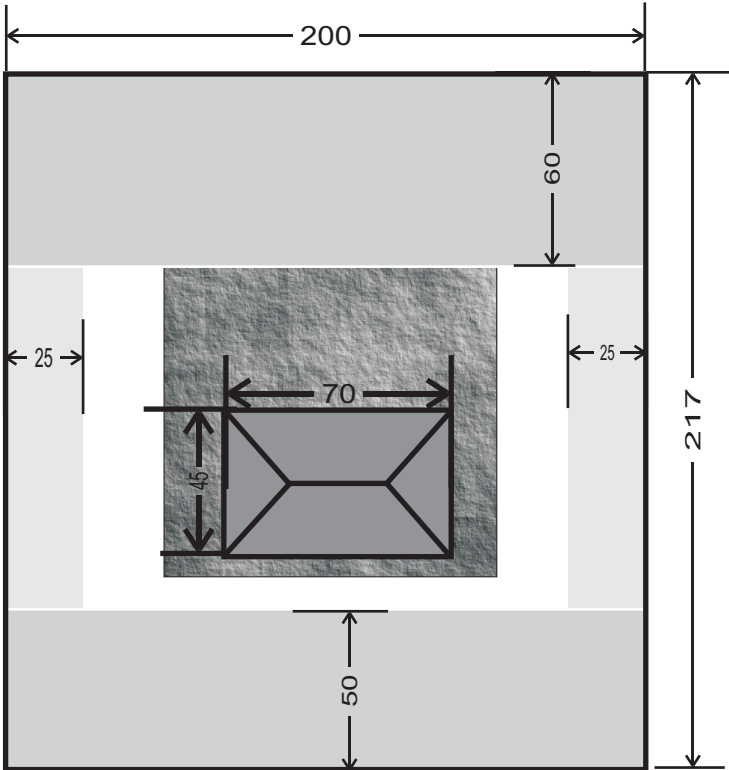

**AC Zoning District**  
 Min Lot Size=43,560 (1 AC.)  
 Max Lot Coverage=10,890 (25%)

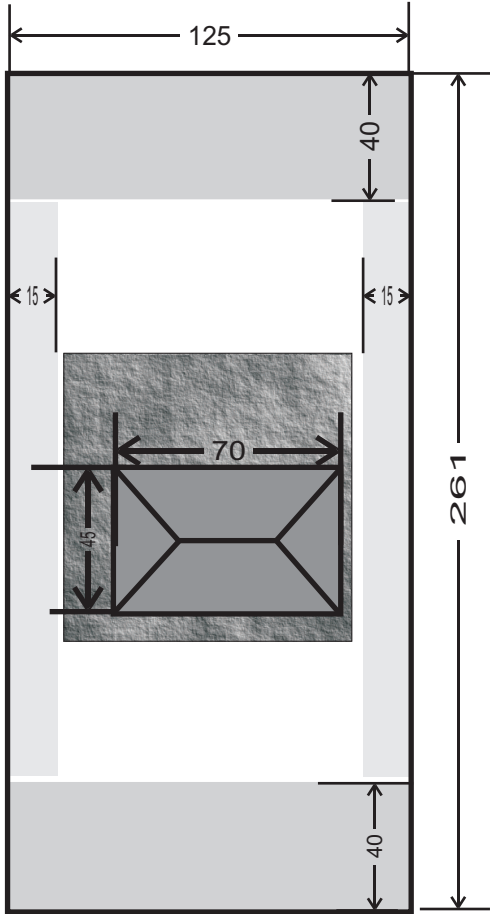

**R-1 Zoning District**  
 Min Lot Size=32,625 (3/4 AC)  
 Max Lot Coverage=8,156 (25%)

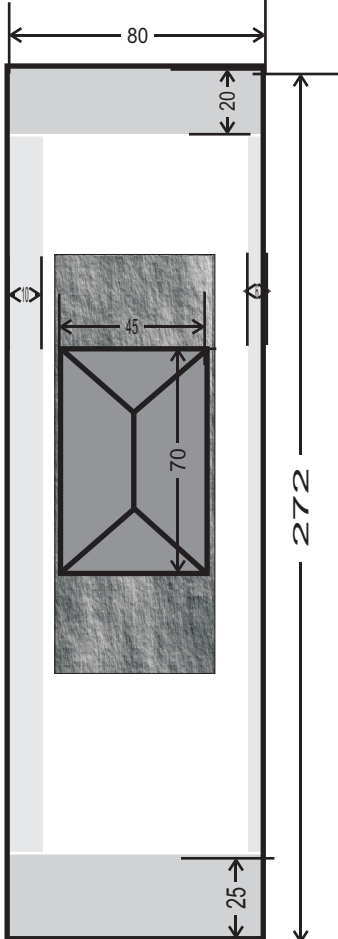

**R-2 Zoning District**  
 Min Lot Size=21,760 (1/2 AC)  
 Max Lot Coverage=6,528 (30%)

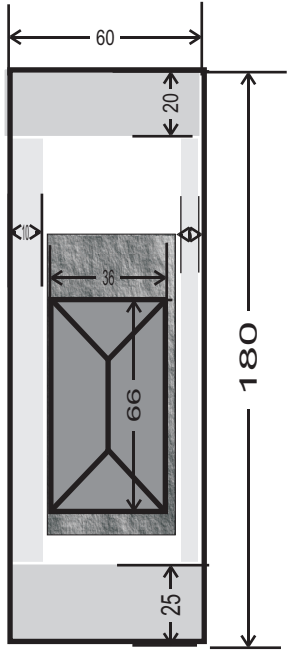

**R-3 Zoning District**  
 Min Lot Size=10,800 (1/4 AC)  
 Max Lot Coverage=3,780 (35%)

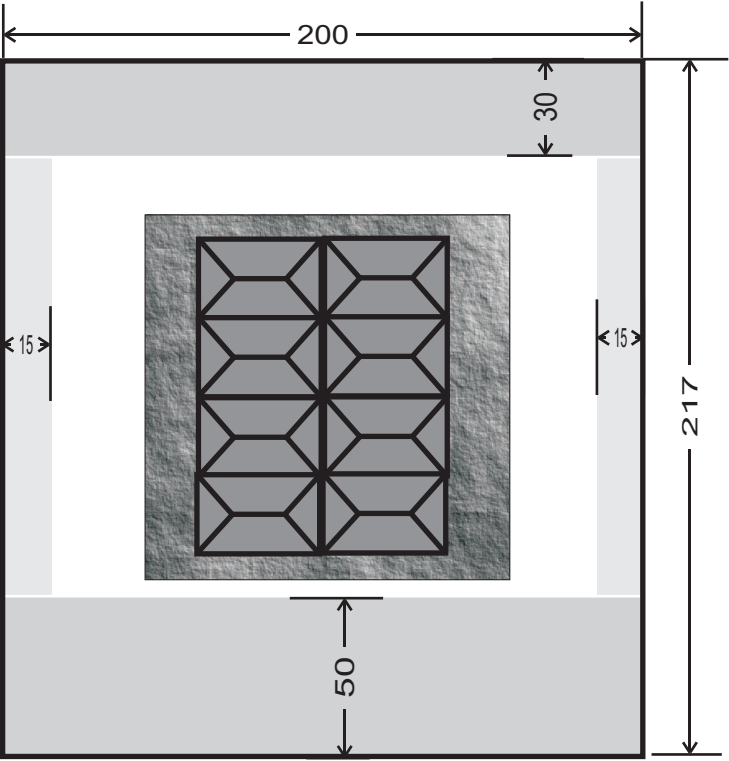

**R-4 Zoning District**  
 Min Lot Size= NA (8 Units Per Acre Max.)  
 Example for 8 Unit Project  
 Max Lot Coverage=13,068 (30%)